

# Preliminary Ordering Procedure

## For pull-only cable controls

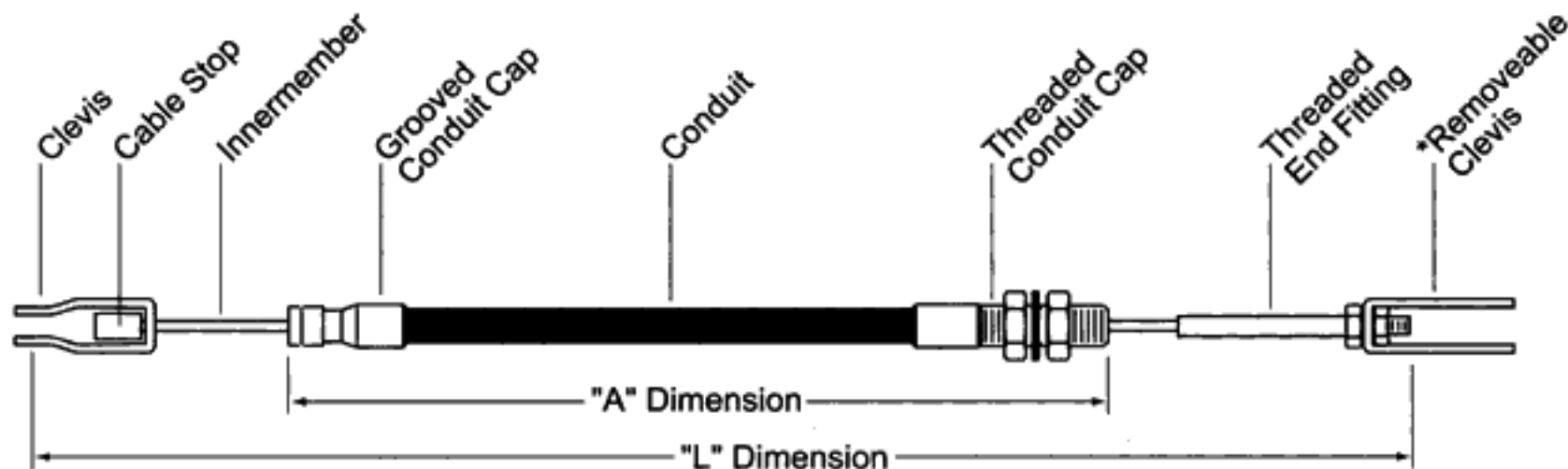

### To specify a pull control, the following information must be given in the order listed:

1. Left innermember end fitting part number.
  2. Left conduit end fitting part number.
  3. Length "A" between conduit fitting reference points in inches.
  4. Right conduit end fitting part number.
  5. Right innermember end fitting part number.
  6. Length "L" of innermember assembly
  7. Travel of the innermember in the conduit in inches. (Note dimensions "L" must be sufficiently greater than dimension "A" to allow desired travel).
- \*Removable items should be listed separately.

### Sample order code:

CS551 - 072 - 54 - 070 - TE505 - 64 $\frac{1}{2}$  - 6

Left innermember end fitting part number ---  
(Clevis end fitting with cable stop)

Left conduit end fitting part number ---  
(Grooved conduit end fitting)

Length of conduit assembly ---  
(54") "A" Dimension

Right conduit end fitting part number ---  
(Threaded conduit end fitting)

Right innermember end fitting part number ---  
(Threaded conduit end fitting)

Length of innermember assembly ---  
(64 $\frac{1}{2}$ ") "L" Dimension

Travel in inches ---  
(6")

# 1500 Pound Series with Lined Conduit

Ultimate load: 1500 lbs

Minimum bend radius: 5"

See page 10 for ordering procedure.

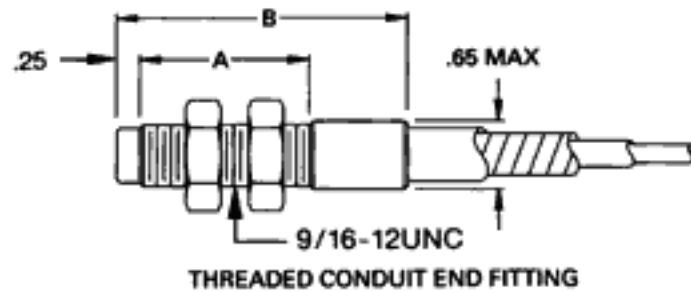
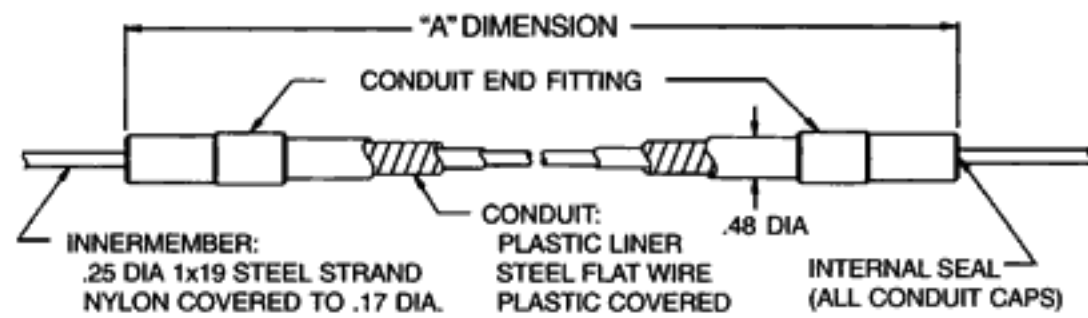

Threaded Conduit End Fitting

Part No.	A	B
060	1.4	2.7
061	2.1	3.4

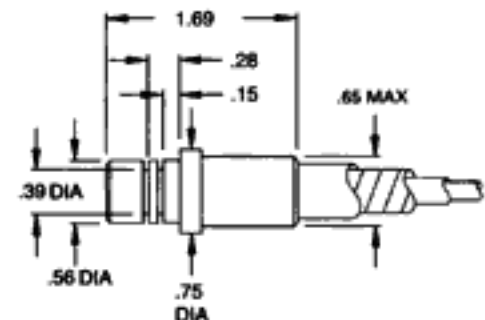

Grooved Conduit End Fitting  
Part No. 064  
Use E-Clip  
175-435-025

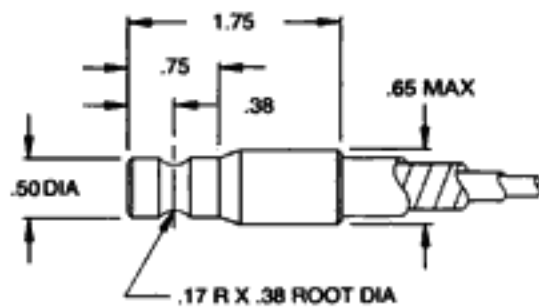

Grooved Conduit End Fitting  
Part No. 062

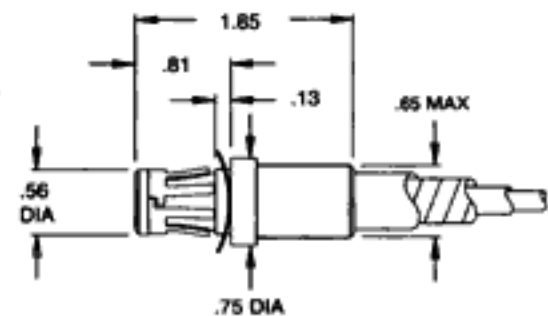

Clip-Lock Conduit End Fitting  
Part No. 065  
For .125 and .187 thick material.

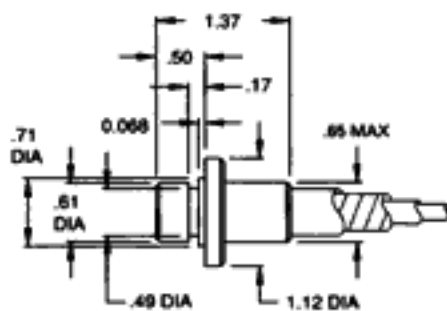

Grooved Conduit End Fitting  
Part No. 026

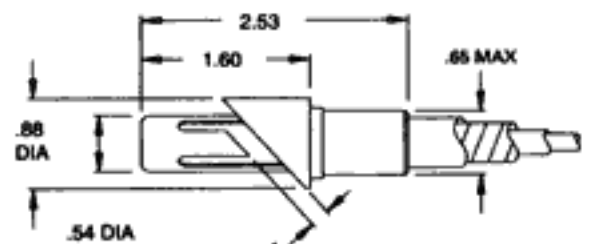

48° Clip-Lock Conduit End Fitting  
Part No. A  
066 .13  
067 .20

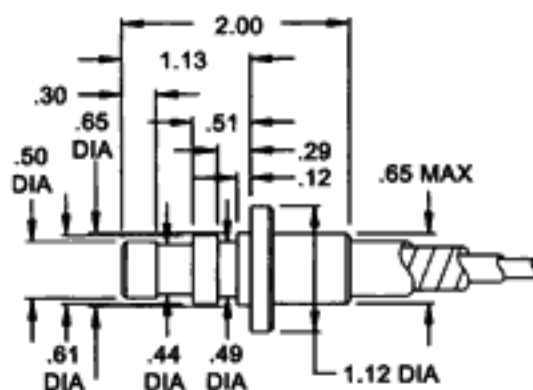

Grooved Conduit End Fitting  
Part No. 027

# 1500 Pound Series

Threaded  
End Fitting

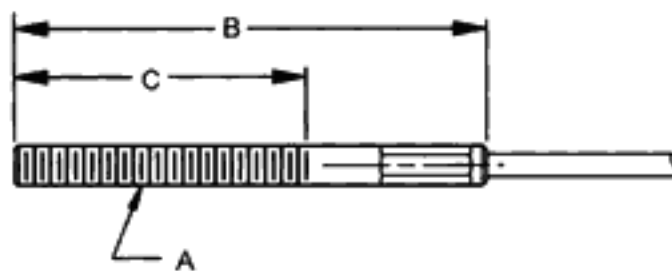

PART NO.	A	B	C
TE 504	5/16-24	3.62	2.25
TE 504-6	5/16-24	2.00	1.00
TE 504-007	5/16-24	6.00	4.63
TE 506	3/8-24	2.62	1.50
TE 523-001	1/4-28	3.62	2.50

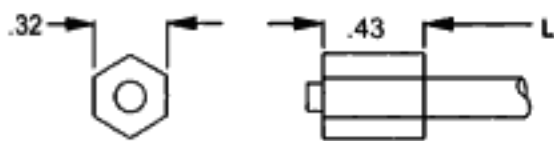

CABLE STOP  
PART NO. BE 520  
(MAX-LOAD 2,000 lbs)

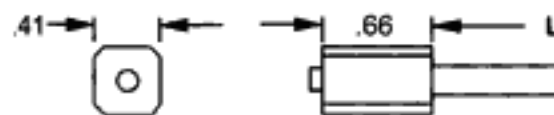

CABLE STOP  
PART NO. BE 501

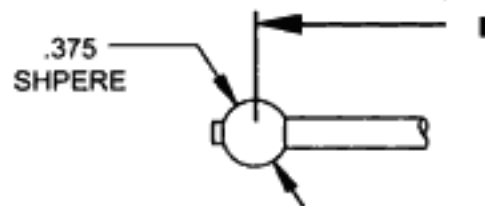

BALL END  
PART NO. BT 821  
(MAX-LOAD 2,000 lbs)

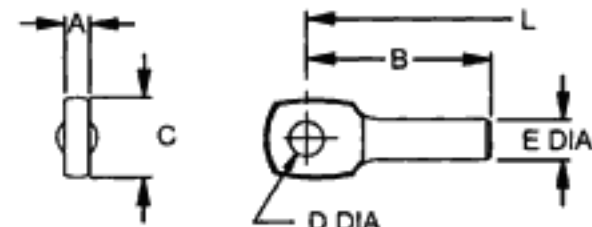

EYE END

PART NO.	A	B	C	D	E
157-047-000	.235	1.81	.75	.323	.375
EE9158	.240	1.60	.75	.500	.437

## Strap Clevis Part Numbers for both 1500 and 3000 series.

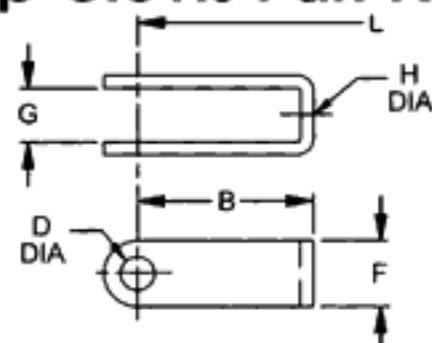

OPEN STRAP CLEVIS	B	D	F	G	H
CS 540	1.62	.31	.62	.43	.266
CS 540-1	1.62	.31	.62	.51	.266
CS 540-6	2.50	.38	.75	.57	.386
CS 540-7	2.50	.31	.62	.51	.266
CS 541	1.94	.38	.75	.51	.266
CS 541-3	1.94	.38	.75	.51	.323
CS 541-5	2.00	.38	.75	.51	.266
CS 541-7	2.50	.38	.75	.51	.266
CS 541-8	2.50	.38	.75	.51	.323
CS 542*	1.08	.50	1.00	.58	.323

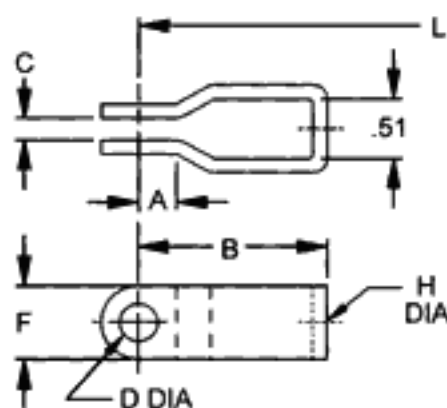

STEP STRAP CLEVIS	A	B	C	D	F	H
CS 550**	.31	1.56	.19	.31	.62	.266
CS 550-1	.31	1.56	.19	.38	.62	.266
CS 550-2	.31	1.56	.19	.31	.62	.316
CS 550-4	.31	1.56	.19	.25	.62	.266
CS 551	.38	1.75	.25	.31	.62	.266
CS 551-1	.38	1.75	.25	.38	.62	.266
CS 551-2	.75	2.38	.25	.31	.62	.316
CS 551-3	.38	1.50	.25	.25	.62	.266
CS 552	.31	2.38	.25	.31	.75	.266
CS 552-1	.31	2.38	.25	.38	.75	.266
CS 552-3	.38	2.38	.25	.43	.75	.316
CS 552-4	.38	2.38	.25	.31	.75	.316
CS 553	.50	1.88	.19	.38	.75	.266

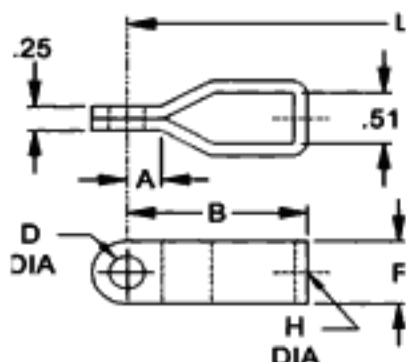

CLOSED STRAP CLEVIS	A	B	D	F	H
CS 562	.31	1.62	.31	.62	.316
CS 563	.28	1.75	.31	.62	.316
CS 564	1.00	2.38	.38	.75	.316

\*Use with 5/16 threaded end rod with nuts only  
\*\*Not available in 3000

# 3000 Pound Series with Lined Conduit

Ultimate load: 3000 lbs.  
Minimum bend radius: 7"

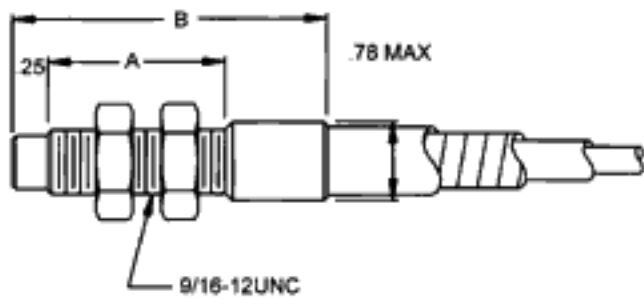
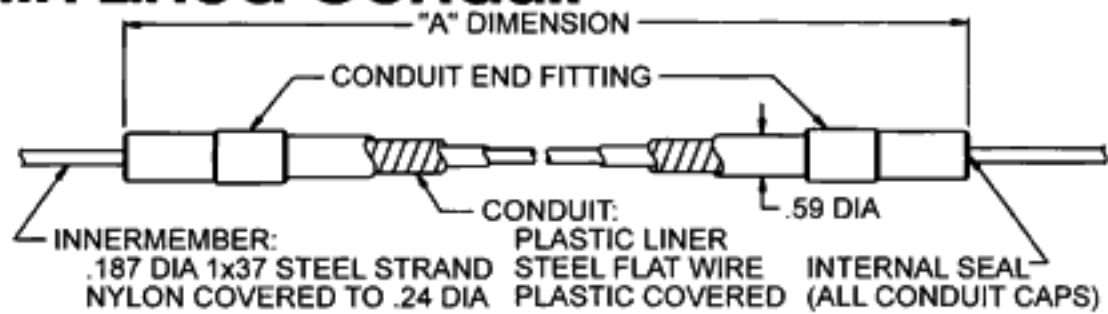

**Threaded Conduit End Fitting**

Part No.	A	B
070	1.4	2.7
071	2.0	3.3

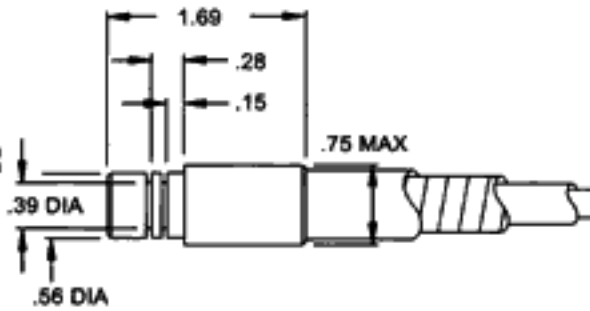

**Grooved Conduit End Fitting**

Part No.	Use E-Clip
074	175-435-025

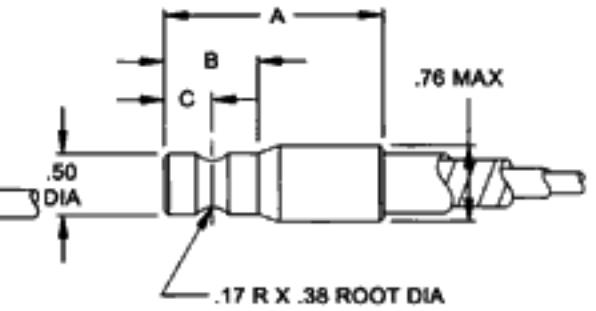

**Grooved Conduit End Fitting**

Part No.	A	B	C
072	1.4	2.7	.38
073	2.0	3.3	.44

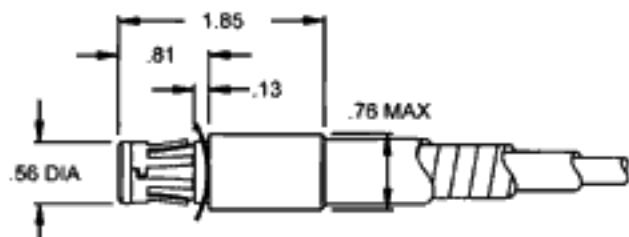

**Clip-Lock Conduit End Fitting**

Part No.
075

For .125 or .187 thick material.

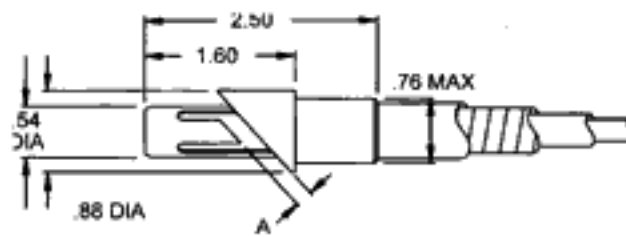

**48° Clip-Lock Conduit End Fitting**

Part No.	A
076	.33
077	.20

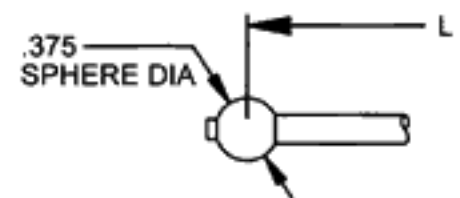

**Ball End**

Part No. BT 822  
(Max-load 2,000 lbs.)

**Threaded End Fitting**

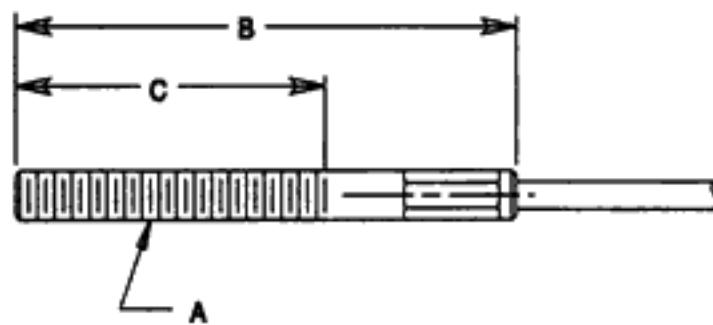

Part No.	A	Swaged	C
TE 505	3/8-24	2.95	2.00
TE 505-1	3/8-24	1.88	1.00
TE 508	3/8-24	2.62	1.50
TE 509-1	3/8-24	4.95	3.75
TE 510-1	5/16-24	2.50	1.50
TE 510-2	5/16-24	3.62	2.24
TE 510-4	5/16-24	4.00	3.00
TE 510-5	1/4-28	3.62	2.50
TE 510-6	5/16-24	2.12	1.00
TE 510-7	5/16-24	2.88	1.50
TE 510-8	5/16-24	5.60	4.47
TE 510-9	5/16-24	3.00	1.91
TE 605	3/8-24	6.00	5.00

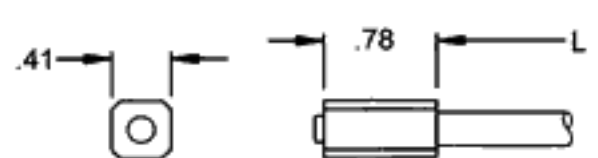

**Cable Stop**

Part No. BE 502

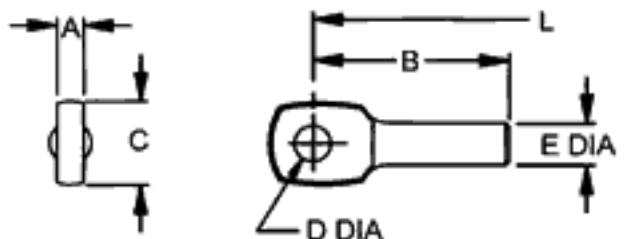

**Eye End**

Part No.	A	B	C	D	E
157-047-002	.235	1.81	.75	.323	.375

# Custom Parking Brake (Pull-only) Cables

Your local cable assembler can create a pull-only cable control for applications such as parking brakes, clutch cables, and other similar applications. 1500 lb. and 3000 lb. series cables available. Choose from conduit caps and end fittings shown here to replace or customize your pull-only cable controls.

Cablecraft has developed a seal system that greatly extends the life of these pull-only control cables. Conduit caps contain a wiper seal to provide maximum protection against the entry of dirt and moisture into the interior of the cable. The innermember is nylon covered, high-tensile galvanized steel strand. The smooth surface of the innermember and the conduit cap seals are the key to extending cable life and efficiency.

The conduit has a plastic liner to provide additional environmental protection. Cablecraft pull-only cables are lubricated during assembly, and because of their design, no further lubrication is required or recommended for the life of the control. Outstanding efficiency is the result of many features incorporated into the Cablecraft design, even after being operated in excess of 250,000 cycles in simulated working conditions.

## Control selection

For proper application of Cablecraft pull controls, the pull input load should be determined as follows:

1. Measure the output load to be operated.
2. Estimate the total number of degrees of bend in the control installation. (Note: bend radius is not significant as long as it is equal or larger than the minimum recommended).
3. Calculate the required pull input load using an efficiency factor obtained from Table #1 and the following equation:  
Input load = output load x efficiency factor.
4. Determine cable size. Individual cable drawings indicate ultimate loads. Allowing a 4-1 safety factor will provide a reliable application and will extend cable life.

## Example Control Selection

1. Max output load to be operated = 380 lbs.
2. Estimated total degrees of bend = 270° F.
3. Calculate required pull input load using Table #1.  
Input load = output load x efficiency factor  
380 lbs. x 1.27 = 483 lbs. input load.
4. Determine cable size:  
Apply your required safety factor to input load (step 3) to determine ultimate load.

Input load	Safety factor	Ultimate load
483 lbs.	x 4	= 1932 lbs.

Refer to following pages for control selection.

### Ultimate Load

1,500 lbs. to 3,000 lbs. see page 14

1,500 lbs. or less see pages 12 and 13

## Your Safety Factor

Each cable size shows the ultimate load. Safety factors are important in proper cable selection. A wide margin (4 to 1 or 5 to 1) between ultimate load and working load is not only safer, but the cable will operate more easily and greatly extends cable life. Detailed information regarding cable selection is available upon request.

## Installation

Care should be exercised to insure that pull controls are installed with conduit end fittings securely fastened to a structural member. The conduit will always be in compression. The total degrees of bend should be minimized for the lowest deflection and friction. On long control runs, the conduit should be clamped to supporting structure at least every 48 inches.

Complete application recommendations will be provided on request. A sketch of the proposed installation will aid in selection of the proper control.

**Table 1**

